

Standard diagnostic and configuration interface for Beckhoff Industrial PCs

As the heart of a manufacturing facility, the Industrial PC is monitored in order to guarantee high plant availability. An additional software tool does not always have to be used for this: this application example describes how monitoring the most important parameters from within TwinCAT or via standardized programming interfaces (OPC, UPnP, .NET, etc.) enables preventive maintenance of Industrial PCs (IPCs). The diagnostic and configuration interface for Beckhoff IPCs accesses all parameters of an IPC by means of MDP (Modular Device Profile) and makes it possible for the user to display critical parameters and to link this information to executable actions.

Uniform access to all parameters of a Beckhoff Industrial PC

In addition to the usual benefits of IPC monitoring within a manufacturing facility, the configuration and diagnostic interface for Beckhoff Industrial PCs can be used to access each parameter of an IPC (hardware, software or application) for reading or writing. Access can take place both from within TwinCAT or via standard programming interfaces such as OPC, UPnP, .NET, etc. Therefore, the parameters of an IPC can be used for plant monitoring in a simple, but effective way. Apart from plant monitoring, the diagnostic and configuration interface can also be used 'remotely,' in order to extremely simplify configuration procedures and to carry out support/service more efficiently. In the case of external access to the IPC (e.g. via LAN), access to the system is password-protected.

IPC monitoring: The 'classic' parameters

The three classic parameters that are suitable for simple and effective monitoring are temperatures, speeds of rotation and voltages on the motherboard: the CPU temperature provides information regarding the

extent of processor utilization and the ventilation quality. Knowing the speed of the fan rotation allows conclusions to be drawn about contamination and possible wear. A check of the various on-board voltages also ensures the smooth operation of the IPC. In addition, the voltage level of the frequently existing lithium battery for the system clock can be checked. Apart from these three parameters, checking the CF cards and RAID systems is important for the trouble-free operation of PC-based controls.

CF card testing tools that require the medium to be removed from the IPC are suitable only in the case of plant standstills, since removing the card entails switching the IPC off. Online monitoring is more convenient and can be accomplished during running operation. The degree of use of the CF card is displayed directly by percentage via the diagnostic and configuration interface for Beckhoff IPCs. Additionally, a message on the screen can suggest a replacement upon falling below a certain limit, so that an exchange can be considered during the next scheduled maintenance.

RAID systems work in the background and are only visible to the user in the operating system as a logical drive that is not distinguishable between the individual hard disks. For monitoring purposes the data in the RAID controller can be accessed, via which the status and the performance of the individual hard disks can be read out. If read/write errors continually occur within the same sector of a disk, then an exchange should be considered.

Recognition of a problem

The decreasing speed of rotation of a CPU fan is a first signal that usually points to strong contamination of the fan and indicates a possible upcoming failure. If the plant operator is informed of this by a pop-up on the screen, then cleaning or replacement of the fan should be considered during scheduled maintenance work and a failure of the IPC due to poor heat dissipation can be avoided. The costs of unplanned downtime are negligible in comparison with this small maintenance job.

However, if there is a large increase in the CPU temperature as the fan speed decreases, one should not wait until the next planned maintenance. Since the IPCs feature an emergency power-off in the case of over-temperature, system failure is imminent in this case without further

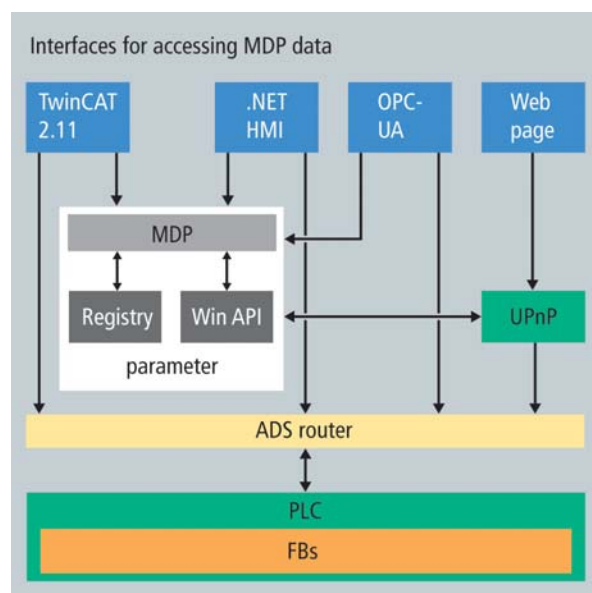

Fig. 1: Accessing parameters

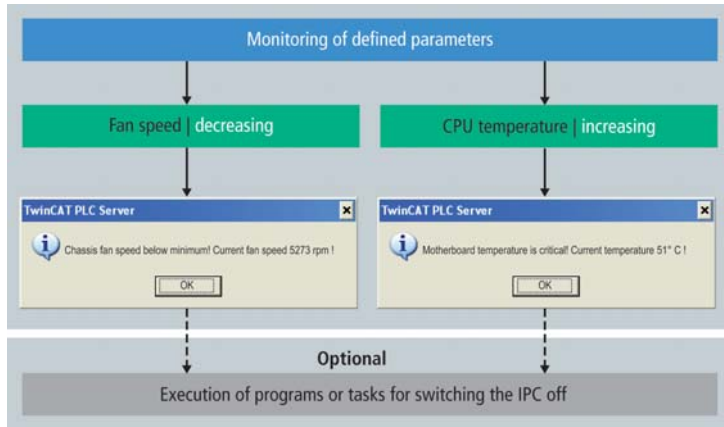

Fig. 2: Analysis of the information, with optional further steps

cooling. If this condition is also indicated by a message, then effective intervention measures can be taken: the emergency power-off is prevented by clear instructions for action, such as the request to switch off the PC or to open the control cabinet doors.

Information on limit values for speeds of rotation, temperatures and voltages for Beckhoff IPCs can be found in the documentation.

IPC monitoring for TwinCAT users: access via the PLC

There are many standard scenarios for the monitoring of an IPC within a manufacturing facility and, for this reason, also many different types of software that can be installed as a separate application on the IPC. The advantage of a system-integrated solution from within the PLC is quite clearly the familiar working environment of a TwinCAT user. Without further familiarization, limit values can be specified within TwinCAT and SMS messages can be generated. If an appropriate parameter is read out cyclically by a function block, then the display of a message upon exceeding a limit value requires only one further function block. Access via TwinCAT is supported from version 2.11 onwards.

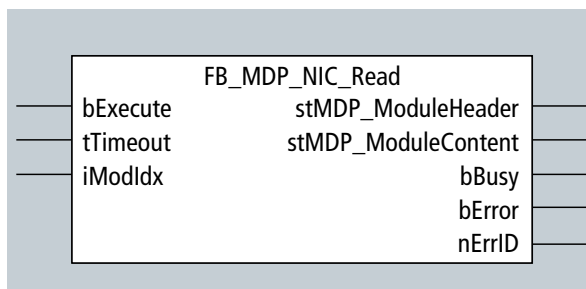

Fig. 3: TwinCAT function block for the readout of parameters

IPC monitoring without TwinCAT: access via interfaces

IPCs and Embedded PCs from Beckhoff are not necessarily linked to TwinCAT; therefore, the use of the diagnostic and configuration interface is not coupled to TwinCAT. The interface is structured according to a uniform layer and is independent from the installed operating system and the employed hardware and programs. The individual hardware, software and application parameters are rasterized and can be accessed

without TwinCAT by means of standard interfaces, such as a webpage, (see fig. 4).

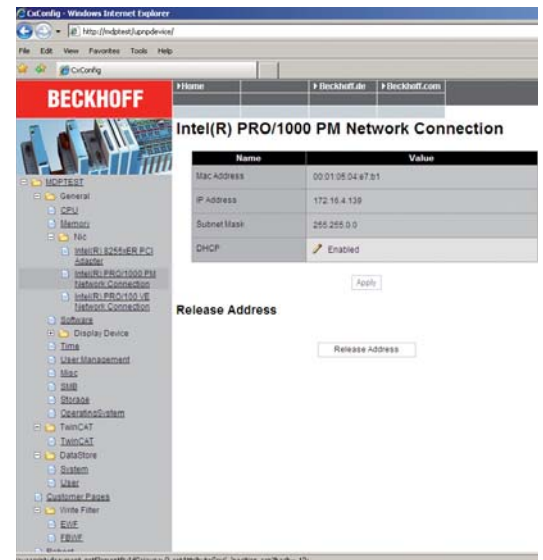

Fig. 4: Querying the MAC-ID

The diagnostic and configuration interface for Beckhoff IPCs thus provides the user with every degree of freedom to make information visible and to use it. In each case, the analysis of the values is up to the user. The user can decide whether they use the parameters only visually or linked logically to other actions.

Application advantage for the customer

- | one-time familiarization with the diagnostic system
- | full continuity on all systems
- | full access to all systems
- | The system is constantly being expanded.

Application examples

1. Simple readout of the actual status
2. Setting of a uniform target status
3. Handling of support and service cases

1. Simple readout of the actual status

Regardless of whether an IPC is installed locally or is located somewhere at the other end of the world, as soon as the IPC is integrated via LAN, all parameters can be read out using the configuration and diagnostic interface for Beckhoff IPCs. Advantage: if the documentation is incomplete or missing, all information on the installed hardware and software versions can be read out via the configuration and diagnostic interface. If a program error only occurs from a certain software release onwards, for example, it is possible to determine which plants require service without telephone calls and travel expenses. The procedure follows the same principle for all fixed data (serial numbers, license key, etc.), since transparent information is available via the configuration and diagnostic interface.

Name	S...	Type	A	Value
Len	0x00	UNSIGNED8	0	0x04
MAC-Address	0x01	Vis-String	2	00:01:05:04:e7:b1
IP-Address	0x02	Vis-String	1	172.16.4.138
Subnet-Mask	0x03	Vis-String	1	255.255.0.0
DHCP	0x04	UNSIGNED8	1	0x01

Fig. 5: Rastering of the parameters by means of MDP

Typical examples for readout are screen resolution, IP addresses, querying the MAC-ID for the IP protection of the software, memory usage of the software, also remotely, etc.

2. Setting of a uniform target status

If uniform pre-settings are to be made from the command level as in the case of Panel PCs, this can be accomplished in a centralized manner with the configuration and diagnostic interface for Beckhoff IPCs. This provides the advantage that all connected terminals have the same status. Furthermore, personnel deployment is minimized, as the update can be performed centrally from one place.

Typical examples, which are distributed centralized to all connected terminals, are the display resolution, IP addresses, PC name, etc.

3. Support and service

Only in the rarest case can the end customer supply concrete information on the software versions in the event of a support inquiry. If the support/service department can directly procure this necessary information itself, then the technical support is better targeted and more effective as a result – one can enter directly. Therefore, the support/service case can be handled faster and with fewer complications.

For further Application Examples please see: www.beckhoff.com/applicationexamples

Technical background to MDP

MDP – what is that?

MDP stands for Modular Device Profile and represents the layout of an Industrial PC (IPC) in an object-oriented and modularized structure. The MDP forms an information model, with which hardware and software components are represented as individual modules. Thanks to MDP, all parameters contained in an IPC – whether operating system, hardware or user software – can be read and changed directly. The modules can thereby be components such as a NIC or a CPU for example; however, software components such as the TwinCAT system are also imaged in the MDP. The layer of the configuration and diagnostic interface for Beckhoff IPCs was based on the specification of the EtherCAT automation protocol.

MDP – what's it for?

If the levels of an IPC are modularized according to a generally accepted pattern, then this fixed structure can be imaged on any IPC, which facilitates configuration and diagnostic procedures. The individual parameters (sub-indices) can be reached by different means of access, depending on the operating system. Via the MDP it is possible to access parameters of the hardware, operating system or application software in order (independent of the CPU, operating system or TwinCAT) to readout and change diagnostic and configuration information. The MDP-based diagnostic and configuration interface is additionally not language-dependent: whether Visual Basic, C++, C# or a PLC library, the MDP can be accessed from any environment using ADS routines (Automation Device Specification). Furthermore, communication with the MDP can take place by UPnP, OPC-UA or also directly by C++ and C#. In principle, access to the data takes place by MDP, as is also the case with regular access procedures, with user authorization and password protection.

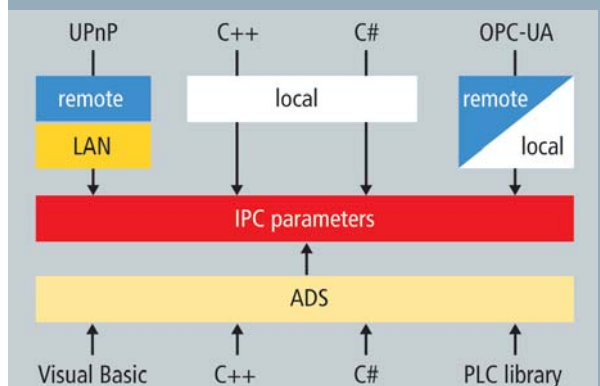

Fig. 6: IPC parameter communication paths