

The Mystère in her element, 43 meters (141 ft) long; built by Vitters Shipyard in Zwartsluis/The Netherlands



Main Hydraulic distribution

CX1000 Embedded PC Hydraulics

Remote I/O BK9000 Ethernet

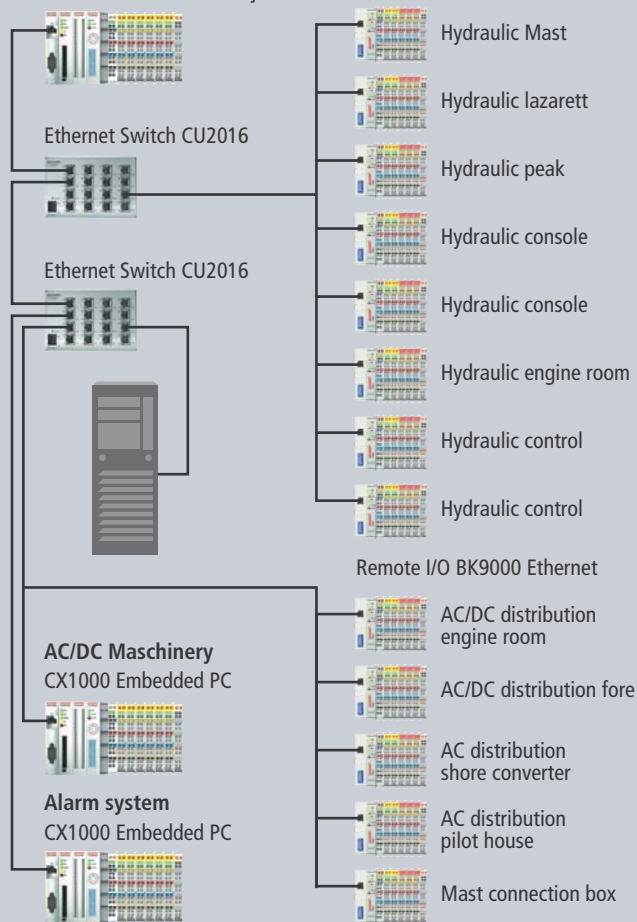

Ethernet-based control technology... on a yacht!

High-tech on board



Control stand of the *Mystère*; the yacht features the same control stand on the port side and on the starboard side. The operating switches for the hydraulic systems can be seen on the right.

→ The *Mystère*, a 43-meter (141 ft) aluminum yacht, was launched in 2006 by Vitters Shipyard in the Dutch town of Zwartsluis. This ultra-modern yacht features drive and control technology one wouldn't normally expect on a luxury boat, including a complex hydraulic system with Beckhoff control components.

The *Mystère* is a luxury yacht that impressively combines speed and comfort. With a crew of six and four separate cabins for the owner and his guests, the yacht is suitable for ocean cruising or occasional participation in sailing competitions.

A fundamental characteristic of the yacht is simple and fast operation of all automated functions. To this end Marble Marine Electronics, based in Urk, Holland, developed an Ethernet-based control system. Three CX1000 Embedded PCs from Beckhoff, which are connected to each other via Ethernet Switches and communicate via six touch screen panels, form the basis of the control system. One CX1000 and eight further Bus Terminal stations with BK9000 Ethernet Bus Couplers control the hydraulic system and all associated components. Two further Embedded PCs control the whole electric system including the alarm system components.

Overall, the network has more than 2,000 I/Os, including 120 analog terminals. Allard Borst, systems engineer at Marble, explains the reasons for using such a high tech solution: "This was the first time we have been working with Beckhoff technology. Our decision was based on the network speed. The Ethernet network offers a speed of 100 Mbit/s. With the real-time Ethernet version from Beckhoff, we also have very fast I/O communication."



- Industrial Automation Link BV www.ial.nl
- Marble Marine Electronics www.marble-me.com
- Vitters Shipyard www.vitters.com