

A new controller concept for wind power converters

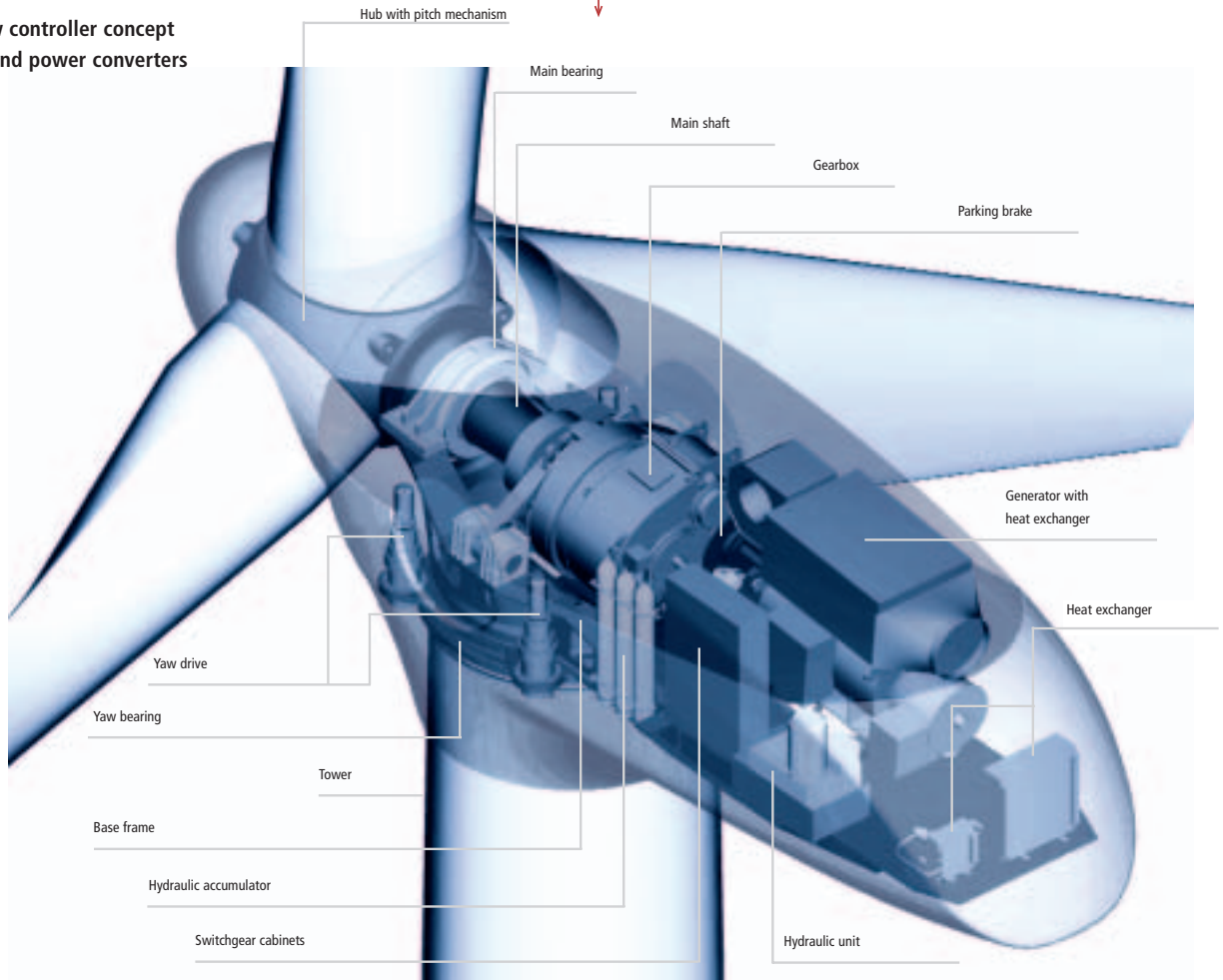

Modern wind power converters possess complex electronic control instrumentation that looks after the operation of the plant, including remote data monitoring, as well as the feed to the power grid. The new DeWind Type D8 wind power converters, utilize a new controller design based on Beckhoff Industrial PCs, TwinCAT automation software, and Bus Terminal technologies.

The wind is blowing in a new direction with TwinCAT

It used to be that the growing number of wind power towers was restricted to coastal regions or to Germany's plateaux. The demand for renewable sources of energy, such as wind power, is becoming more and more important throughout Europe. Within a few years, 50% of Europe's entire electrical power should be generated from renewable sources. In the year 2000, the number of wind power converters in operation had already reached 9,369, representing a total power of around 6 GW. This meant that 2.5% of German electricity was obtained from wind power. The first wind farms out at sea are already being designed. To ensure future growth, the wind power industry must respond to energy planners demands for larger converters to be installed in diversified locations. The fact that Germany politically is one of the leading promoters of wind power technology does not hurt the growth of the industry. The manufacturers' job is to develop their wind power converters into versions that are fully competitive with con-

ventional methods of power generation while the political environment favors them. The new 2 MW converter from DeWind AG, Germany, also known as "the D8", is a first step in that direction. The PC-based control technology from Beckhoff makes its own contribution to this.

Wind energy converter delivers up to two megawatts

The DeWind D8, generating a rated power of 2 MW from its 80 m diameter rotor follows the DeWind D6 series, generating 1.25 MW. The D8 features a high power yield, quiet operation, good grid compatibility, long service life and attractive design. DeWind AG plans to produce about 30 units of this flagship product in this year. It is forecasted that 100 wind power converters will be built annually, from 2003 onwards. A first project is currently being implemented at Siestedt, Germany.



The DeWind D8

With this addition to their range of products, DeWind is serving new markets and their specific profiles. The next steps in the development process have already been taken. The DeWind D8, with its 2 megawatts of rated power, has a rotor diameter of 80 meters, and is offered in tower versions with hub heights at 80 or 95 meters. The D8 is pitch-controlled, and is operated with variable rotation speeds.

The new generation of DeWind converters are characterized by highest yields and reliable operation. The blades, drive train, gearings, generator and frequency converter are closely matched to one another.

Key figures:

- | Rated power 2,000 kW
- | Rotor diameter 80 m
- | Swept area 5,017 m²
- | Variable speed
- | Power limitation by means of pitching (FSP)
- | Double-feed induction generator
- | Cut-in wind speed 3 m/s
- | Nominal wind speed 13.5 m/s
- | Hub height 80 or 95 m
- | Structure-borne noise insulation through vibration elements in the drive train

→ www.dewind.de

It is not just the external dimensions of the D8 that are setting new standards in wind power technology; the controller solution is also opening up new possibilities. The tasks of a wind power converter controller are both very complex and extremely varied. Four servomotors and hydraulically operated brakes take care of the azimuth control, i.e. the adjustment for the wind direction. The D8 is also fitted with a fast pitch regulation system, in which the rotor blades are rapidly but gently adjusted to the available wind or to the power requirements of the power supply company if operating at full capacity. A very important point in the control of wind power converters is grid monitoring and control of the power feed via a frequency converter. In parallel with these tasks, the environmental conditions, temperatures and pressures in the hydraulic system, rotation speeds and vibrations are all monitored.

The potential for development of proprietary controllers has been exhausted

Controller solutions have, until now, consisted of a large number of microcontrollers and proprietary bus systems. Robert Müller, Electrical Construction Manager at DeWind AG stated: "The development capacity of the controllers for wind power converters generally found on the market has come to the end of the line. Their performance is limited, and their resources are exhausted. The difficulties of interfacing the various functional units such as the controller, the remote data transmission systems and in-house production and planning systems in their present state can not effectively be overcome". This means that the control systems used today can only with great difficulty fulfill their tasks in relation to controlling the converter, managing the network and remote diagnostics – the significance of which will continue to grow in the future. In addition to this it must be borne in mind that conventional controllers have only limited resources, and can therefore only offer restricted monitoring and diagnostic functions. They are not able to grow to meet future demands. "This is, however, unacceptable in the light of the increasing demands placed on wind power converters and manufacturers", continued Robert Müller. "Customers expect significantly better analysis and diagnostic facilities. Power grid operators, furthermore, specify flexible network management with fast reaction times, in particular for wind farms". The first goal of the technological development work was to improve the efficiency of the converters, reduce the loading and increase the convenience of operation for the sake of greater profits and reduced costs.

DeWind is following a radical, new controller philosophy, with regard to the D8. Information that might originate in control of the frequency converter and of the power converter – generated in each case by closed systems with incompatible functions and approaches to communication – would have to be read via entirely separate communication paths, and a great deal of effort would have to be expended to bring them into a proper relationship if, for instance, they were need-

ed for diagnostic purposes. The use of open, standardized software and hardware should obviate problems originating with lack of compatibility.

D8 – controlled by TwinCAT

A Beckhoff Industrial PC running the TwinCAT automation software performs all control tasks of the D8. Around 200 I/Os distributed over the nacelle and the base of the tower are passed through the Bus Terminal system to the PC controller. The real-time requirements of the system for general control and regulation lie in the range of a deterministic cycle time of 10 ms; for power feeding and monitoring task, the time is around 1 ms. This is possible with the C6220 Control Cabinet PC. This is entirely assembled without moving parts. The mass storage system consists of a Flash drive, and because of the low power consumption in the processor and power supply unit there is no need for a fan. The usual PC interfaces such as graphic card, RS 232, USB and Ethernet are mounted directly on the processor card.

The mains network monitoring and the link to the frequency converter located in the base of the tower are implemented via CANopen through the 2-channel FC5102 PC Fieldbus Card. The master card contains a NOVRAM to save the work-

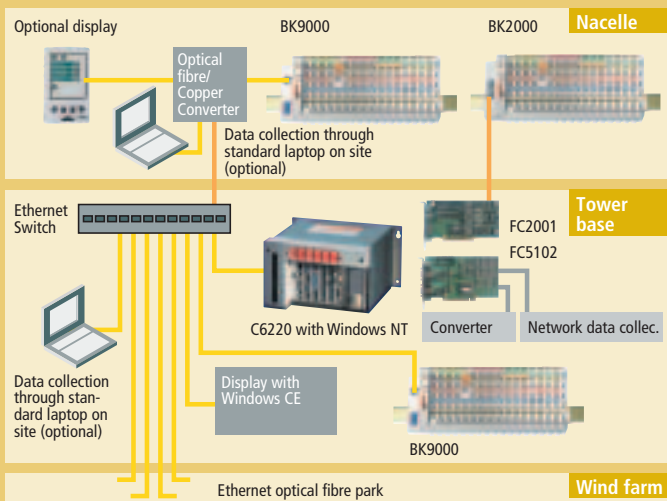

The crucial point for DeWind AG was that the black box controller needed to be opened up, and that the software developed should integrate the specific operating control with the design of the plant. The synergy generated in this way between mechanical development and software development is a milestone in the development of DeWind converters.





ing data. The Lightbus is used to transfer the signals within the nacelle with no risk of electromagnetic interference. The Bus Terminals are here connected through optical fibers and the FC2001 Lightbus Card to the Industrial PC located in the base of the tower. An additional Bus Terminal station in the nacelle is connected via an Ethernet optical fiber cable to the controller. This again demonstrates the flexibility of the software PLC/NC TwinCAT, supporting any common fieldbus system (even simultaneously!).

Programming standards ease project planning

Dewind wind power experts used the powerful TwinCAT development environment meeting IEC 61131-3 for the PLC programming. This meant that all the control and regulation tasks could be implemented in an open programming interface. The application software was therefore truly DeWind's own in-house development. The open platform offered by the Industrial PC also simplifies the continuously growing need for compatible interfaces to the outside world. Application adjustments, due to unexpected developments or discoveries, are very easy because the hardware and software components allow for limitless changes to the controller making.

Wind power installations in wind farms can communicate with one another and be configured without difficulty. Additional measuring instrumentation can be integrated at any time, and does not have to be operated in parallel. TwinCAT can easily handle the exchange of information using existing features. The manufacturers, operators and owners of wind power converters need increasing amounts of information. This information can be economically transferred across the Internet. Therefore, with Beckhoff "New Automation Technology" detailed infor-

mation from every single I/O point can be obtained, and if necessary parameterized. Commissioning and servicing of the equipment also becomes easier. The program code can easily be debugged, even online. Important characteristic figures relating to the wind power converter are recorded according to the cascade method, and can be called up at any time. This allows important conclusions to be drawn relative to the early detection of damage, and in the long run this can result in higher plant availability. The operators of wind power converters must perform additional tasks for the power supply companies, who presently specify flexible network management with fast reaction times. Whereas formerly these converters needed to be taken off the grid when they were experiencing problems, they are presently expected to support the grid. This calls for the implementation of highly complex algorithms, and these can be handled in real-time using TwinCAT's high computing power.

Competitive wind power

With the D8 control system, DeWind AG can offer customized service packages for their customers. That include converter monitoring, with a free choice of analysis and display variations. The system guarantees a much higher reliability in feeding the mains grid to the power supply companies, while at the same time its high capacity satisfies customers' growing demands for clean energy from wind power at every location. With the D8, DeWind AG have succeeded in using an open system platform to adapt the control technology to the requirements of the future. While maintaining compatibility with proven international standards, it allows both the hardware and software to be freely scaled. Beckhoff provides the tools to meet these demands.